

zone 2-22 & zone 1-21



ATEX Group II, Zone 2 and 22, Category 3 GD

Islands series 501	
Features	157-158
501 Specifications	159-160
How to Order - Assembly Kit	161
How to Order - Subbases / Valves	162-163
How to Order - Accessories	164
How to Order - G3 Electronics	165
How to Order - Connectors	166
ATEX certification	183



Islands series 502	
Features	168-175
501 Specifications	175-172
How to Order - Assembly Kit	173
How to Order - Subbases / Valves	174
How to Order - Accessories	175
How to Order - G3 Electronics	176
How to Order - Connectors	177
ATEX certification	183

G3 Electronics	
Features	179-180
G3 Platform Distribution Options	181-182
ATEX certification	183
DeviceNet™	184
EtherNet/IP™	186
Modbus TCP	188
Profibus-DP®	190
PROFINET®	192
EtherNet/IP™ DLR	194
Inputs Modules - Digital Inputs - 5-Pin M12 Modules	196
Inputs Modules - Analog Inputs (16 Bit Resolution)	196
Inputs Modules - Digital Inputs - Terminal Strip Modules	196
Inputs Modules - Accessories	197
G3 Backplane Extension Modules	199
G3 Backplane Extension Cables and Connectors	201
Dimensions - G3 Fieldbus Communication Assembly	202-203
How to Order - G3 Electronics	204



580 Electronics, 501 & 502 Series	
Summary	205

Cabinet Mounting, 501 Series	
Features	233
How to Order	236

ATEX Group II, Zone 1 and 21, Category 2 GD

Series 622	
Features	229
Dimensions	232





G3 Electronic displays its innovations !



Innovative Graphic Display is used for easy commissioning, visual status & diagnostics

Commissioning Capabilities

- Set network address
- Set baud rate
- Set auto or manual I/O sizes
- Set fault/idle output states
- Set factory defaults

Visual Diagnostics

- Shorted and open load detection
- Shorted sensor/cable detection
- Low & missing power detection
- Missing module detection
- Self-tests activation

Graphic Display for configuration & diagnostics



Easy, Robust Connections



Benefits:

- Power connector scheme allows output power to be removed while inputs and communication are left active
- IP65 Protection
- Novel “clip” design allows easy module removal/replacement without dismantling manifold
- Interfaces to valves with flow from 400 up to 650 l/min ANR
- “On line” CAD files, 85 formats

01440GB-2017/R02
Availability, design and specifications are subject to change without notice. All rights reserved.



Easy, Cost Effective Solutions for Digital I/O and Valve Automation using G3 Electronics

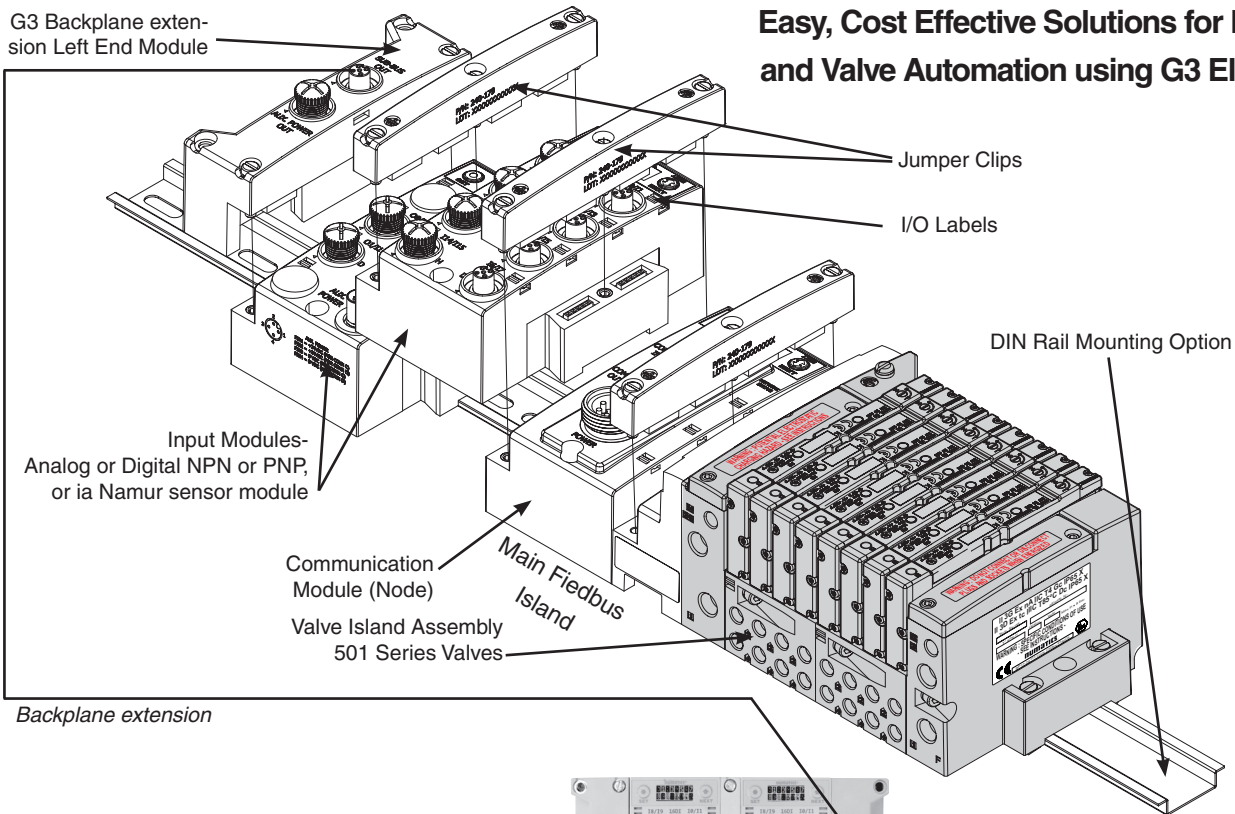

Backplane extension

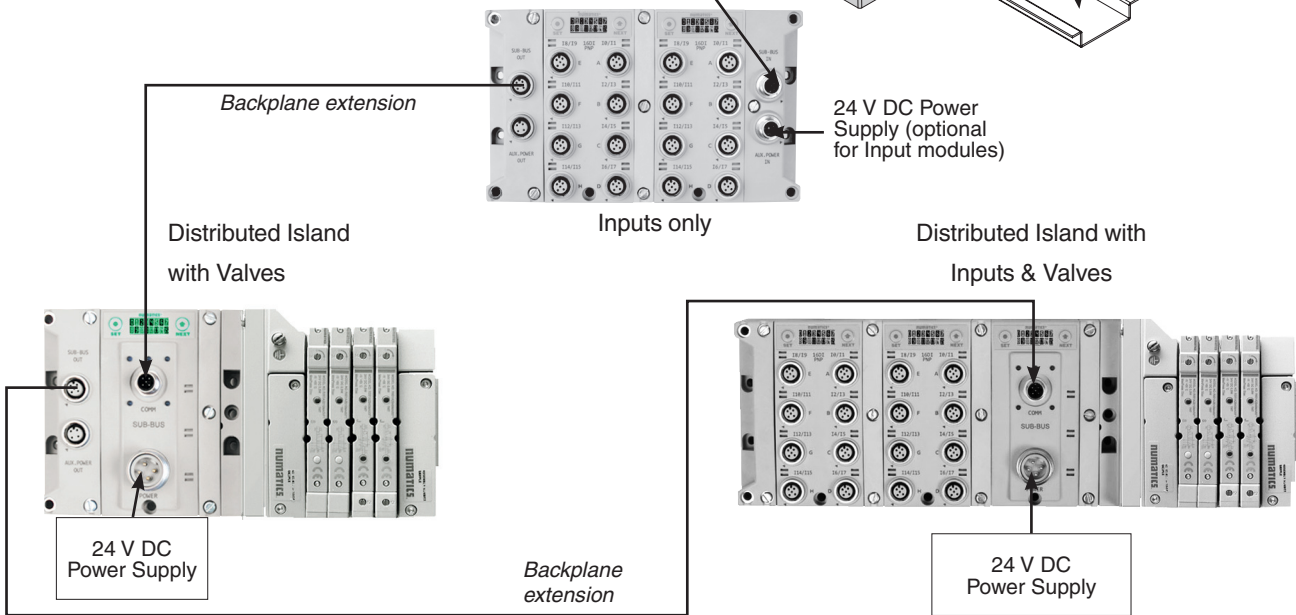

Distribution Benefits:

- Up to 256 input / 544 output (1200 bits) capability with one communication node (or address)
- Up to 16 distributed manifolds, with max. 30 m backplane extension length
- Input modules connectable to valve side
- ia Namur sensor
- Analog or digital inputs (PNP or NPN)
- Distributed plug & play design, no configuration required

Supported protocols:

- DeviceNet™
- Ethernet/IP™
- Modbus TCP
- PROFIBUS-DP®
- PROFINET®
- EtherNet/IP™ DLR

Pneumatic characteristics:

- 5/2 monostable or bistable, 5/3 and dual 3/2 spool valves
- Valve module width: 11 mm
- Flow rates: 400 l/min (ANR)
- Plug-together flexibility for easy exchange of valves without pneumatic or electrical disconnection
- IP65 protection

Operating Data:

- 100% ED: 24 V DC
- Power: G3 (inrush/holding): 0,82 W/0,33 W
580/599 (cold/hot) : 0,7 W/0,8 W

⚠ The power consumption of each block of distributed modules must not exceed 20 W.

⚠ Each distributed modules must have its own power supply connection (24 V DC).



FEATURES

- High flow rate up to 400 l/min
- Wide electrical connection selection : G3 or 580 Fieldbus Electronics, 25 or 37 Pin Sub-D connector, 19 Pin Round connector or Terminal Strip
- Internal or external pilot pressure supply capability
- Version with integrated LED and electrical protection. LED indicator visible from 3 sides
- Solenoid air operated valves for use in potentially explosive atmospheres according to ATEX-Directive, zone 2 or zones 2-22
- 580 Electronics

GENERAL

Operating pressure See «SPECIFICATIONS» [1 bar =100 kPa]
Ambient temperature range (TS) See «SPECIFICATIONS»
Rated flow See «SPECIFICATIONS»
 conforming to ISO 6358 C (5/2) = 1,45 x 10⁻⁸ m³/s.Pa (sonic conductance)
 b (5/2) = 0,40 (critical pressure ratio)
Pneumatic base 3 & 4 station subbases
Connection Joinable subbase
Response time See «SPECIFICATIONS»



fluids (*)	temperature range (TS)	technology	seal materials (*)
air or inert gas ISO 8573 Level 7.4.4	-10°C to +50°C	rubber packed	FPM (fluoroelastomer)

CONSTRUCTION

MATERIALS IN CONTACT WITH FLUID	
(*) Ensure that the compatibility of the fluids in contact with the materials is verified	
Body	Zamak, E-coating treatment
Spool	Aluminium
Piston	POM
Spring	Stainless steel
Other seals	NBR
Other materials	PAM (polyarylamide) , GF 50% (glass fiber reinforced)
Subbases	Aluminium, E-coating treatment

ELECTRICAL CHARACTERISTICS

Coil insulation class	F
Electrical safety	IEC-EN 60730-1 / IEC-EN 60730-2-8
Electrical enclosure protection	IP65 (EN 60529)
Standard voltages	DC (=) : 24V
Power ratings (=)	G3: 0,81 W/0,33 W (inrush/holding) 580 CHARMs: 0,81 W/0,33 W (inrush/holding) 580/599: 0,7 W / 0,8 W (hot/cold)

01440GB-2017/R02
Availability, design and specifications are subject to change without notice. All rights reserved.



SPECIFICATIONS

15-DIGIT PRODUCT CODE

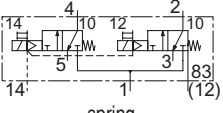
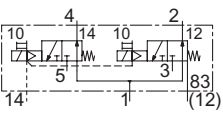
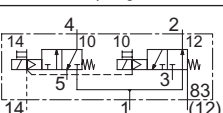
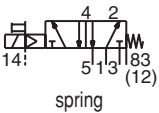
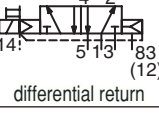
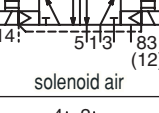
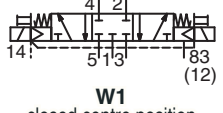
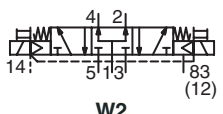
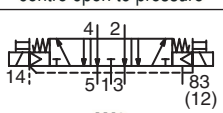
function	type	symbol pilot (14) return (12)	rated flow		response time open / closed (ms)	pilot pressure at 23°C (bar)		operating pressure port 1		
			at 6,3 bar ΔP 1 bar l/min (ANR)			min.	max.	min.	max. (PS)	
			1 → 2 1 → 4	2 → 3 4 → 5	air (*)				=	
SPOOL VALVE, RUBBER PACKED TECHNOLOGY, WITH IMPULSE MANUAL OPERATOR										
2 x 3/2 NC	K	 spring	405	415	18 / 18	(a)	8	2	8	R501A2BD0M71WF1
2 x 3/2 NO	N	 spring	400	400	18 / 18	(a)	8	2	8	R501A2BA0M71WF1
2 x 3/2 NC - NO	H	 spring	460 450	470 450	18 / 18	(a)	8	2	8	R501A2BC0M71WF1
5/2	S	 spring	405	410	14 / 29	2	8	-0,95	8	R501A2B10M71WF1
	M	 differential return	405	410	25 / 21	2	8	-0,95	8	R501A2BN0M71WF1
	J	 solenoid air	405	410	11 / 11	2	8	-0,95	8	R501A2B40M71WF1
5/3	G	 W1 closed centre position	405	410	13 / 12	2	8	-0,95	8	R501A2B60M71WF1
	B	 W2 centre open to pressure	405	360	17 / 38	2,5	8	-0,95	8	R501A2B70M71WF1
	E	 W3 centre open to exhaust	365	415	27 / 12	2	8	-0,95	8	R501A2B50M71WF1

Pp = Pilot pressure

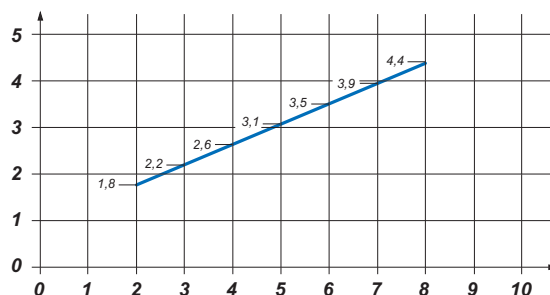

P1 = Working pressure

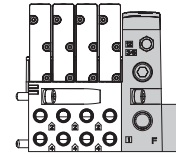
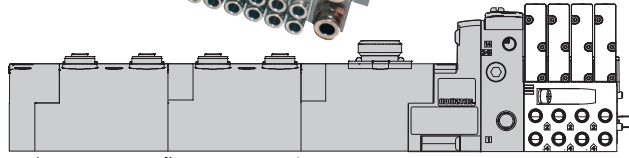
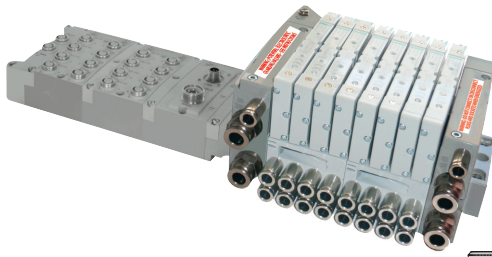

0, 1.. 2

[Configurator - CAD Files](#)

How to Order
Manifold assemblies kit (Electronic + End plate)

15-DIGIT PRODUCT CODE

G 501 A V 3 H 1 00 V A36

Thread connection

- G = ISO 228/1
- 8 = NPT (contact us)
- K = Push-in connectors

Product series

501 (11 mm valve)

Revision letter

A = Initial release

Product type

V = Valve Manifold Assembly

Electronics

- 8 = 580 Fieldbus Electronics
- D = CHARMs Electronics
- 3 = G3 Fieldbus Electronics
- J = 25 Pin Sub-D Connector
- M = 37 Pin Sub-D Connector
- Q = 19 Pin Round Connector
- T = Terminal Strip 1-32

Number of Valve Stations

501			
A = NA/33	I = 9/41	Q = 17	Y = 25
B = NA/34	J = 10/42	R = 18	Z = 26
C = 3/35	K = 11/43	S = 19	2 = 27
D = 4/36	L = 12/44	T = 20	3 = 28
E = NA/37	M = 13/45	U = 21	4 = 29
F = 6/38	N = 14/46	V = 22	5 = 30
G = 7/39	O = 15/47	W = 23	6 = 31
H = 8/40	P = 16/48	X = 24	7 = 32

ATEX options

2-22 (3GD) IP65X	2-22 (3GD) IP54X	2 (3G) IP54X
A36 ⁽¹⁾	A41 ⁽¹⁾	A43 ⁽¹⁾
D36 ⁽²⁾	D41 ⁽²⁾	D43 ⁽²⁾
D38 ⁽³⁾	D42 ⁽³⁾	D44 ⁽³⁾
F16 ⁽⁴⁾	F18 ⁽⁴⁾	F19 ⁽⁴⁾

- ⁽¹⁾ Internal pilot W/O DIN Rail Mount
- ⁽²⁾ DIN Rail Mount
- ⁽³⁾ External pilot supply from port 14
- ⁽⁴⁾ External pilot supply from port 14 and DIN Rail Mount

End Plate Style

V = Vertical

End Plate Port Size (1-3-5)

Used with the first digit «G» or «8»:

1 = 1/8 (female thread only)

Used with the first digit «K»:

H = 6 x 8 mm (push-in connector)

input modules ⁽¹⁾ (G3/ATEX)	501 max. coils ⁽¹⁾
0	0,81 W/0,33 W
1	32
2	
3	
4	
580	18
580 CHARMs	48
	0,7 W/0,8 W
25 Pin Sub-D Connector	22
37 Pin Sub-D Connector	24
Terminal Strip 1-32	24
19 Pin Round Connector	16

⁽¹⁾ Do not exceed the max. number of pilot solenoid valves authorised.



Max power consumption per block: 20 W



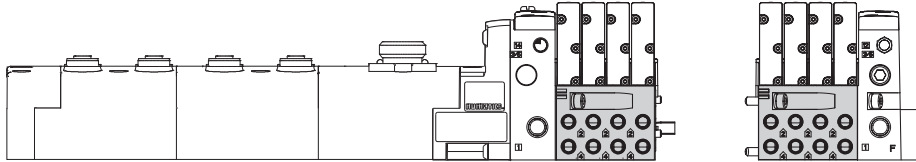
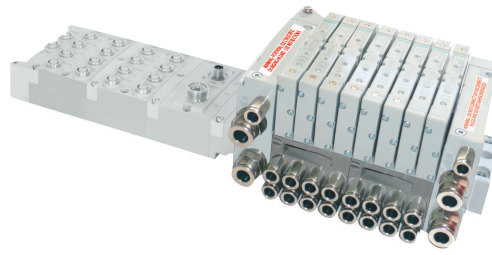

**How to Order
Subbases**

15-DIGIT PRODUCT CODE

H 501 A M S4 2 M 71W 1 0

Thread connection

H = Metric thread
K = Push-in connectors

Product series

501 (11 mm valve)

Revision letter

A = Initial release

Product type

M = Manifold base
Z = Mid station supply
F = 32+ Solenoid Manifold Subbase

Mounting

S3 = Manifold base, 3 stations, side port, single Z-Board™
M3 = Manifold base, 3 stations, side port, double Z-Board™
S4 = Manifold base, 4 stations, side port, single Z-Board™
M4 = Manifold base, 4 stations, side port, double Z-Board™

Not use

Interface

1 = High flow

ATEX options

71W = Standard (zone 2 or zones 2-22)

Wiring option

M = Plug-in

Port connection

B = M7 (female thread only)
D = 2,7 x 4 mm [push-in connector only]
(Mid station supply not available)
F = 4 x 6 mm [push-in connector only]

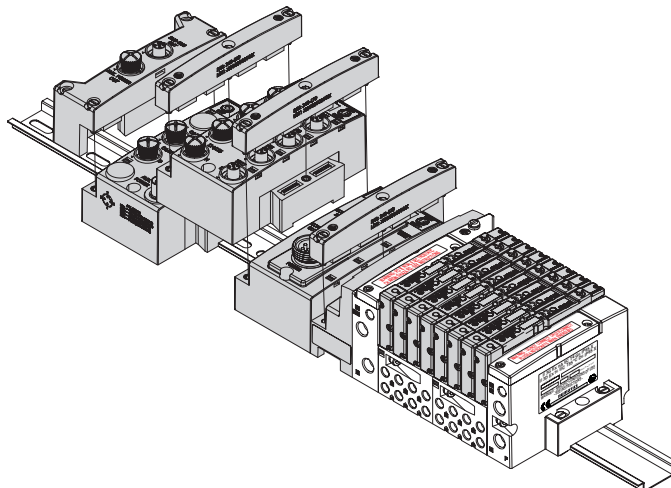

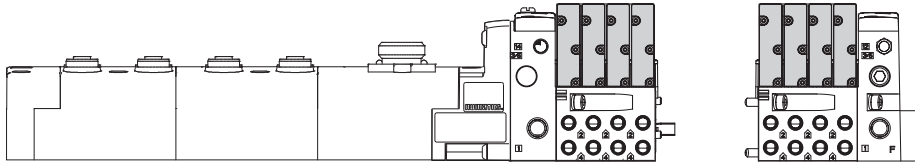
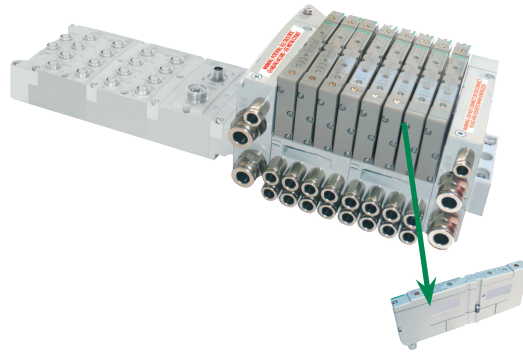

How to Order

Valves

15-DIGIT PRODUCT CODE

R 501 A 2 B 4 0 M 71W F1

Thread connection
R = Pad mount

Product series
501 (11 mm valve)

Revision letter
A = Initial release

Actuation
2 = Rubber packed

Valve type
B = Solenoid pilot

Function
A = 2x3/2 NO, dual 3-way
C = 2x3/2 NCx NO, dual 3-way
D = 2x3/2 NC, dual 3-way
F = 2x3/2 NOxNC, dual 3-way
N = 5/2, Differential air return
1 = 5/2, spring return
4 = 5/2, solenoid air return
5 = 5/3, W3, open center to exhaust
6 = 5/3, W1, center closed
7 = 5/3, W2, open center to pressure

Voltage - class
F1 = 24 V DC - class F

ATEX options (zone 2 or zones 2-22)
71W = With impulse manual operator
82L = With maintained manual operator
84A = Without manual operator



Electrical interface
M = Plug-in (with LED indicator / DC)

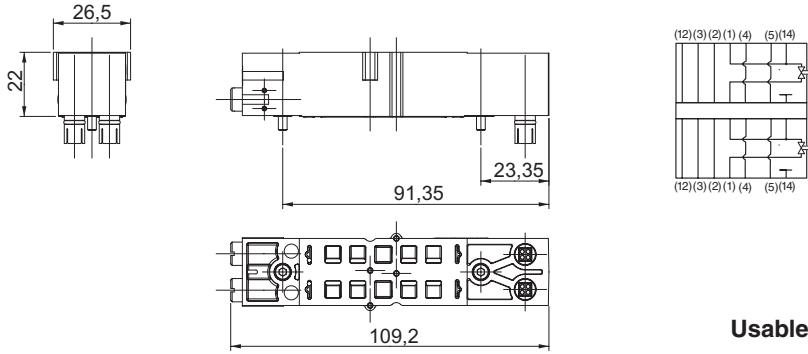

Sandwich shut off block

- Used to shut-off pressure to the valve which is mounted above it.
- Allows easy maintenance without the need to shut-off pressure to the whole manifold.
(provided for 2x3/2 NC-NC valve)



Usable only for internal pilot supply island

Pay attention to residual pressures

The valve(s) should not be energised during disassembly

15-DIGIT PRODUCT CODE	Description	weight (kg)
R501AY428501001	Sandwich shut off block (double)	0,11

HOW TO ORDER [ATEX options (zone 2 or zones 2-22)]
 Consult the online configurator - CAD files on: www.asco.com



How to Order

G3 Electronics

G3 EP1 00 D 0 71W

Electronics Protocols

- DN1** = DeviceNet™
- ED1** = EtherNET/IP DLR
- EM1** = EtherNet ModBus®/TCP
- EP1** = EtherNet/IP™
- PT1** = PROFIBUS DP
- PN1** = PROFINET
- DS2** = Backplane extension Valve Manifold
- DS3** = Backplane extension I/O Assembly

Number of I/O Modules

- 00** = 0
- 01** = 1
- 02** = 2
- 03** = 3
- 04** = 4

ATEX:
 4 modules max. per bloc.

ATEX options

- 71W** = Version ATEX
- D45** = 71W + DRM-DIN Rail Mounting
- D46** = 71W + E23-Fieldbus assembly without valves
- F20** = 71W + E23-Fieldbus assembly without valves + DRM-DIN Rail Mounting

Left Mounting

- D** = w/ Backplane extension Out
- H** = w/ Terminating Resistor

Modification

- 0** = Initial release

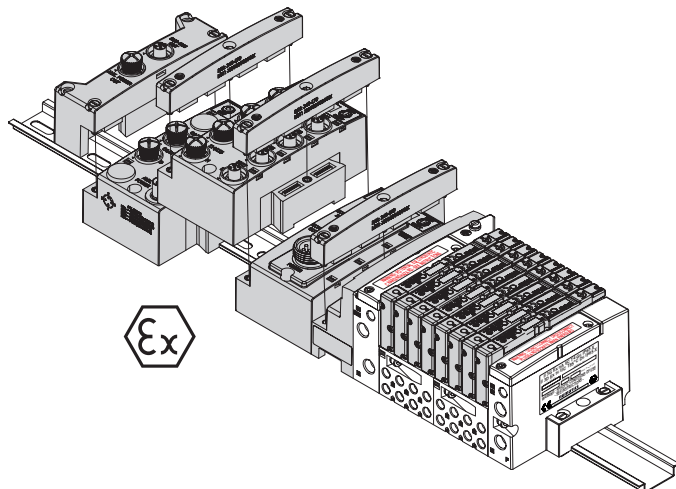



Connectors

Accessory type	Designation	Code
	25 Pin Sub-D Female Connector (500 series)	w/ cable 2 m NDB25F22U02MSB3
		w/ cable 5 m NDB25F22U05MSB3
		w/ cable 10 m NDB25F22U10MSB3
	37 Pin Sub-D Female Connector (500 series)	w/ cable 2 m NDB37F22U02MSB3
		w/ cable 5 m NDB37F22U05MSB3
		w/ cable 10 m NDB37F22U10MSB3
	19 pin female M23 connector, straight (500 and 2000 series)	w/o cable 88164102
		w/ cable 5 m 88164106
	19 pin female M23 connector, 90° elbow (500 and 2000 series)	w/o cable 88164105
		w/ cable 5 m 88164107

NDB25F22U02MSB3 NDB25F22U05MSB3 NDB25F22U10MSB3
Pin 1 : white
Pin 2 : brown
Pin 3 : green
Pin 4 : yellow
Pin 5 : grey
Pin 6 : pink
Pin 7 : blue
Pin 8 : red
Pin 9 : black
Pin 10 : purple
Pin 11 : grey/pink
Pin 12 : red/blue
Pin 13 : white/green
Pin 14 : brown/green
Pin 15 : white/yellow
Pin 16 : yellow/brown
Pin 17 : white/grey
Pin 18 : grey/brown
Pin 19 : white/pink
Pin 20 : pink/brown
Pin 21 : white/blue
Pin 22 : brown/blue
Pin 23 : white/red
Pin 24 : brown/red
Pin 25 : white/black

NDB37F22U02MSB3 NDB37F22U05MSB3 NDB37F22U10MSB3
Pin 1 : white
Pin 2 : brown
Pin 3 : green
Pin 4 : yellow
Pin 5 : grey
Pin 6 : pink
Pin 7 : blue
Pin 8 : red
Pin 9 : black
Pin 10 : purple
Pin 11 : grey/pink
Pin 12 : red/blue
Pin 13 : white/green
Pin 14 : brown/green
Pin 15 : white/yellow
Pin 16 : yellow/brown
Pin 17 : white/grey
Pin 18 : grey/brown
Pin 19 : white/pink
Pin 20 : pink/brown
Pin 21 : white/blue
Pin 22 : brown/blue
Pin 23 : white/red
Pin 24 : brown/red
Pin 25 : white/black
Pin 26 : brown/black
Pin 27 : grey/green
Pin 28 : yellow/grey
Pin 29 : pink/green
Pin 30 : yellow/pink
Pin 31 : green/blue
Pin 32 : yellow/blue
Pin 33 : green/red
Pin 34 : yellow/red
Pin 35 : green/black
Pin 36 : yellow/black
Pin 37 : grey/blue